

SIZE	15mm to 900mm above on request.
END	FE / SE / SW / BW
RATING / CLASS	150 / 300 / 600 / 900 / 1500 / 2500 / PN 10 - PN 16
OPERATION	Manual Hand Wheel / Gear / Electrical Actuator / Pneumatic Actuator / Cylinder
MOC	WCB, SS, FORGE STEEL, ALLOY STEEL

MATERIALS OF PARTS

NO	Part Name	ASTM Materials		
		Carbon Steel	1 ¼ cr- ½ mo	18Cr-9Ni-2Mo
1	Body	A216-WCB	A217-WC6	A352-LCB
2	Bonnet	A216-WCB	A217-WC6	A352-LCB
3	Wedge	A216-WCB + CR13	A217-WC6 + HF	A352-LCB + C13
4	Stem	A182-F6a	CR-MO-V	A182-F6a
5	Seat Ring	A105 + CR13	A182-F11 + HF	A350-LF2 + CR13
6	Stem Backseat	A276-420	A276-304	A276-420
7	Bonnet Gasket	Spiral Wound (Graphite+304)		
8	Bonnet Stud	A193-B7	A193-B16	A320-420
9	Bonnet Stud Nut	A194-2H	A194-7	A194-4
10	Packing	Graphite		
11	Gland	A276-420	A276-304	A276-420
12	Gland Flange	A216-WCB	A217-WC6	A352-LCB
13	Eyebolt Pin	Carbon Steel	A276-420	Carbon Steel
14	Eyebolt	Carbon Steel	A193-B7	Carbon Steel
15	Eyebolt Nut	Carbon Steel	A193-2H	Carbon Steel
16	Grease Fitting	Brass + Steel		
17	yokesleeve	Aluminum-Bronze		
18	Yokesleeve Jan Nut	Carbon Steel		
19	Handwheel	Malleable Iron		
20	Handwheel nut	Carbon Steel		

CLASS 150

SIZE	2	2½	3	4	6	8	10	12	14	16	18	20	24	26	28	30	32	36	in
	50	65	80	100	150	200	250	300	350	400	450	500	600	650	700	750	800	900	mm
L (RF)	7.00	7.50	8.00	9.00	10.50	11.50	13.00	14.00	15.00	16.00	17.00	18.00	20.00	22.00	24.00	24.00	28.00	28.00	in
	178	191	203	229	267	292	330	356	381	406	432	457	508	559	610	610	711	711	mm
L1 (BW)	8.5	9.50	11.12	12.00	15.88	16.50	18.00	19.75	22.50	24.00	26.00	28.00	32.00	34.00	36.00	36.00	38.00	40.00	in
	216	241	283	305	403	419	457	502	572	610	660	711	813	864	914	914	965	1016	mm
H (Open)	15.25	17.00	18.88	23.00	30.50	37.62	45.50	53.12	59.38	67.00	74.50	83.50	98.25	110.50	116.50	124.00	129.00	146.50	in
	386	434	480	584	765	956	1149	1350	1508	1703	1892	2119	2500	2806	2960	3150	3280	3720	mm
DO	8	8	10	12	12	14	16	15	20	22	24	26	29	29	32	32	38	40	in
	200	200	250	300	300	350	400	450	500	550	600	640	700	720	800	800	950	1000	mm
WT (kg.)	18	25	32	50	77	121	178	265	463	463	621	792	1521	1521	1838	2261	2490	3310	RF
	15	18	26	41	69	108	156	248	424	524	587	752	1570	1770	1900	3310	2540	3380	BW

CLASS 300

SIZE	2	2½	3	4	6	8	10	12	14	16	18	20	24	26	28	30	32	36	in
	50	65	80	100	150	200	250	300	350	400	450	500	600	650	700	750	800	900	mm
L (RF)	8.50	9.50	11.12	12.00	15.88	16.50	18.00	19.75	30.00	33.00	36.00	39.00	45.00	49.00	53.00	55.00	60.00	68.00	in
	216	241	283	305	403	419	457	502	762	838	914	991	1143	1245	1346	1397	1524	1727	mm
L1 (BW)	9.12	10.12	11.75	12.62	16.50	17.12	18.60	20.38	30.62	33.62	36.62	39.75	45.88	50.00	54.00	56.00	61.12	69.12	in
	232	257	298	321	419	435	473	518	778	854	930	1010	1165	1270	1372	1422	1553	1756	mm
H (Open)	16.12	17.88	20.00	24.00	31.75	39.38	47.62	55.75	62.25	67.88	77.12	86.38	102.00	117.00	122.00	126.00	130.00	152.00	in
	410	453	509	612	805	1000	1210	1415	1580	1725	1960	2195	2590	2975	3100	3200	3300	3860	mm
DO	8	8	10	12	14	16	18	20	22	22	24	26	29	29	32	32	38	40	in
	200	200	250	300	350	400	450	500	550	550	600	640	720	720	800	800	950	1000	mm
WT (kg.)	23	35	50	71	144	209	322	482	683	950	1145	1635	2660	3090	3310	3595	3720	3985	RF
	17	26	39	53	113	164	256	390	565	805	965	1410	2305	2540	2725	3055	3360	3630	BW

CLASS 600

SIZE	2	2½	3	4	6	8	10	12	14	16	18	20	24	26	28	30	32	36	in
	50	65	80	100	150	200	250	300	350	400	450	500	600	650	700	750	800	900	mm
L (RF)	11.50	13.00	14.00	17.00	22.00	26.00	31.00	33.00	35.00	39.00	43.00	47.00	55.00	57.00	61.00	65.00	70.00	82.00	in
	292	330	356	432	559	660	787	838	889	991	1092	1194	1397	1448	1549	1651	1778	2083	mm
L1 (BW)	11.62	13.12	14.12	17.12	22.12	26.12	31.12	33.12	35.12	39.12	43.12	47.25	55.38	57.50	61.50	65.50	70.62	82.62	in
	295	333	359	435	562	664	791	841	892	994	1095	1200	1407	1461	1562	1664	1794	2099	mm
H (Open)	16.50	18.75	20.38	25.50	33.00	40.38	48.38	57.00	62.00	70.62	76.00	87.00	101.50	105.00	109.50	114.00	124.00	140.00	in
	418	476	518	646	840	1025	1230	1450	1575	1795	1930	2210	2580	2665	2780	2890	3150	3560	mm
DO	8	10	10	12	18	20	24	24	24	24	26	26	29	29	32	32	38	40	in
	200	250	250	300	450	500	600	600	600	600	640	640	720	720	800	800	950	1000	mm
WT (kg.)	36	52	67	112	170	393	610	890	1245	1530	1965	2450	2995	3475	3725	4045	4185	4480	RF
	29	42	53	83	125	310	472	730	1055	1240	1625	2030	2590	2855	3065	3440	3780	4085	BW

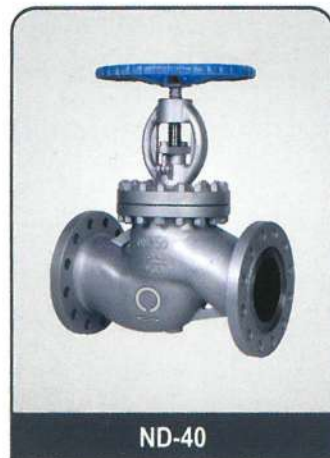
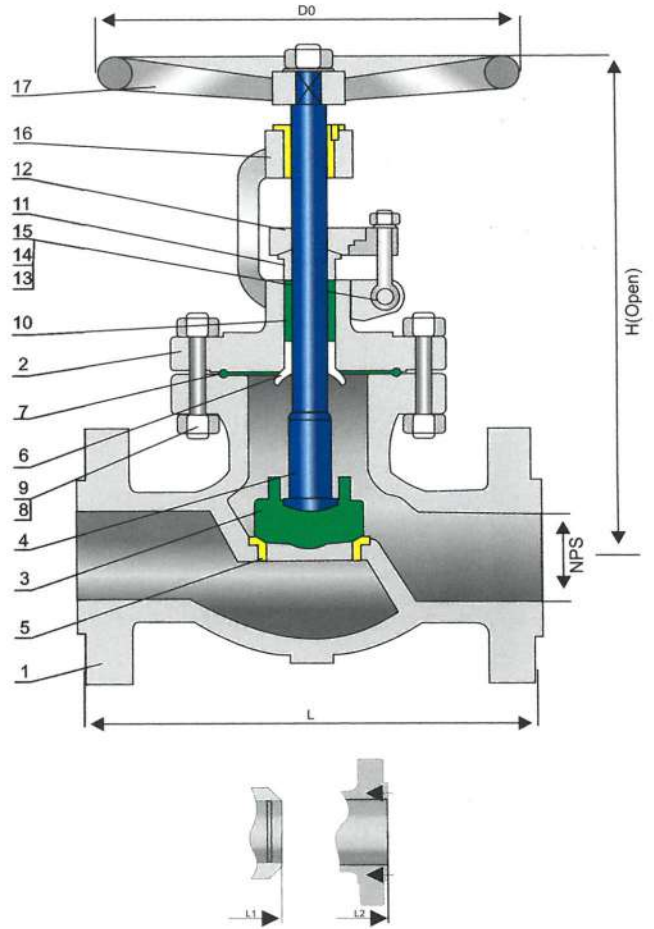

SIZE	15mm to 600mm above on request.
END	FE / SE / SW / BW
RATING / CLASS	150 / 300 / 600 / 900 / 1500 / 2500 / ND-40 / PN 10 - PN 16
OPERATION	Manual Hand Wheel / Gear / Electrical Actuator / Pneumatic Actuator / Cylinder
MOC	WCB, SS, FORGE STEEL, ALLOY STEEL

MATERIALS OF PARTS

NO	Part Name	ASTM Materials		
		Carbon Steel	1 ¼ cr- ½mo	Carbon Steel
1	Body	A216-WCB	A217-WC6	A352-LCB
2	Bonnet	A216-WCB	A217-WC6	A352-LCB
3	Disc	A105 + CR13	A182-F11 + HF	A350-LF2 + CR13
4	Stem	A182-F6a	CR-MO-V	A182-F6a
5	Seat Ring	A105 + HF	A182-F11 + HF	A350-LF2 + HF
6	Stem Backseat	A276-420	A276-304	A276-420
7	Bonnet Gasket	Steel Ring	304SS Ring	Steel Ring
8	Bonnet Stud	A193-B7	A193-B16	A320-L7
9	Bonnet Stud Nut	A194-2H	A194-7	A194-4
10	Packing		Graphite	
11	Gland	A276-420	A276-304	A276-420
12	Gland Flange	A216-WCB	A217-WC6	A352-LCB
13	Eyebolt Pin	Carbon Steel	A276-420	Carbon Steel
14	Eyebolt	Carbon Steel	A193-B7	Carbon Steel
15	Eyebolt Nut	Carbon Steel	A194-2H	Carbon Steel
16	Yokesleeve		Aluminum-Bronze	
17	handWheel		Malleable Iron	

CLASS 150

SIZE	2	2½	3	4	6	8	10	12	14	16	in
	50	65	80	100	150	200	250	300	350	400	mm
L/L1 (RF/BW)	8.00	8.50	9.50	11.50	16.00	19.50	24.50	27.50	31.00	36.00	in
	203	216	241	292	406	495	622	698	787	914	mm
L2 (RTJ)	8.00	8.50	9.50	11.50	16.00	19.50	24.50	27.50	31.00	36.00	in
	203	216	241	292	406	495	622	698	787	914	mm
H (Open)	15.00	21.00	17.50	20.25	22.00	24.25	32.00	35.88	48.38	57.00	in
	380	535	445	515	560	615	815	910	1230	1450	mm
DO	7	10	11	11	13	13	16	18	20	24	in
	180	240	280	280	320	320	400	450	500	600	mm
WT (kg.)	18	30	41	64	86	110	280	380	510	740	RF
	14	22	33	43	72	88	245	345	450	665	BW

CLASS 300

SIZE	2	2½	3	4	6	8	10	12	14	16	in
	50	65	80	100	150	200	250	300	350	400	mm
L/L1 (RF/BW)	10.50	11.50	12.50	14.00	17.50	22.00	24.50	28.00	-	-	in
	267	292	318	356	444	559	622	711	-	-	mm
L2 (RTJ)	11.12	12.12	13.12	14.62	18.12	22.62	25.12	28.62	-	-	in
	282	308	333	371	460	575	638	727	-	-	mm
H (Open)	16.75	19.00	19.88	22.50	25.25	33.25	35.50	38.62	-	-	in
	425	485	505	570	640	845	900	980	-	-	mm
DO	8	10	11	13	16	18	20	24	-	-	in
	200	240	280	320	400	450	500	600	-	-	mm
WT (kg.)	25	32	38	56	96	150	360	550	-	-	RF
	20	22	27	41	75	117	310	492	-	-	BW

CLASS 600

SIZE	2	2½	3	4	6	8	10	12	14	16	in
	50	65	80	100	150	200	250	300	350	400	mm
L/L1 (RF/BW)	11.50	13.00	14.00	17.00	22.00	26.00	31.00	33.00	-	-	in
	292	330	356	432	559	660	787	838	-	-	mm
L2 (RTJ)	11.62	13.12	14.12	17.12	22.12	26.12	31.12	33.12	-	-	in
	295	333	359	435	562	663	790	841	-	-	mm
H (Open)	17.50	19.75	21.00	24.50	29.50	36.50	44.88	53.12	-	-	in
	445	502	533	622	750	927	1140	1350	-	-	mm
DO	10	11	13	16	18	20	24	24	-	-	in
	240	280	320	400	450	500	600	600	-	-	mm
WT (kg.)	35	50	60	110	230	410	770	1140	-	-	RF
	27	34	42	84	192	350	680	1030	-	-	BW

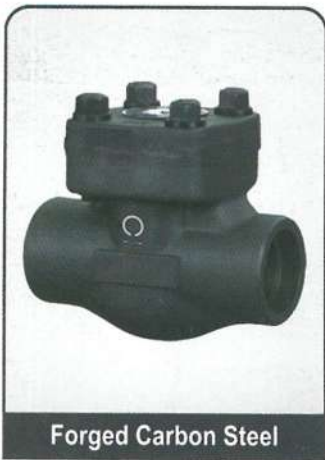
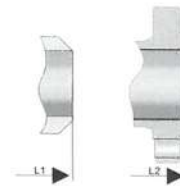
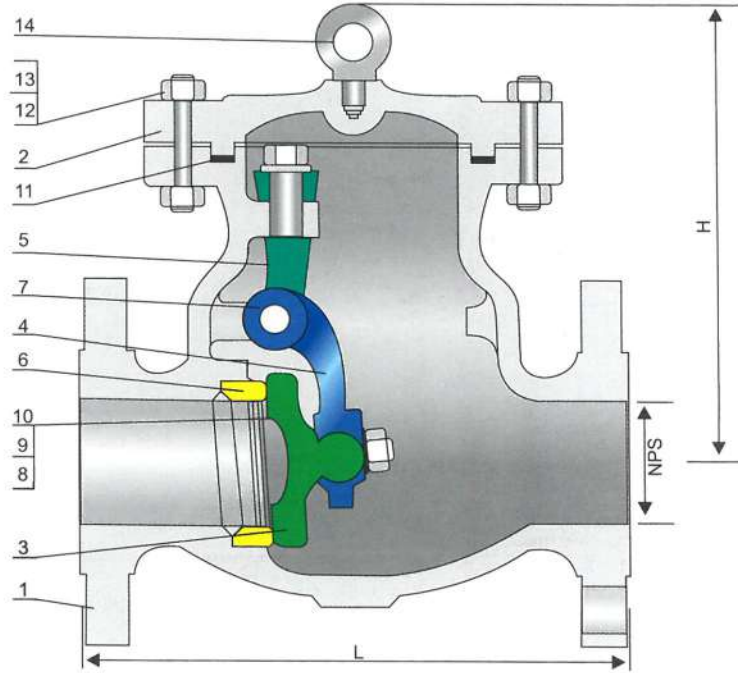

SIZE	15mm to 750mm above on request.
END	FE / SE / SW / BW
RATING / CLASS	150 / 300 / 600 / 900 / 1500 / 2500 / ND-40 / PN 10 - PN 16
MOC	WCB, SS, FORGE STEEL, ALLOY STEEL

MATERIALS OF PARTS

NO	Part Name	ASTM Materials		
		Carbon Steel	18cr.-9nimo	Carbon Steel
1	Body	A216-WCB	A217-WC6	A352-LCB
2	Cover	A216-WCB	A217-WC6	A352-LCB
3	Disc	A105-CR13	A182-F11 + HF	A350-LF2 + CR13
4	Hinge	A216-WCB	A217-WC6	A352-LCB
5	Fork Part	A216-WCB	A217-WC6	A352-LCB
6	Seat Ring	A105 + CR13	A182-F11 + HF	A350-LF2 + CR13
7	Hing Pin	A276-420	A276-304	A276-420
8	Disc Washer	Carbon Steel	A276-304	Carbon Steel
9	Disc Nut	Carbon Steel	A194-7	Carbon Steel
10	Disc Nut Pin	Carbon Steel	A276-420	Carbon Steel
11	Gasket	Spiral Wound (Graphite+304)		
12	Stud	A193-B7	A193-B16	A320-L7
13	Stud Nut	A194-2H	A194-7	A194-4
14	Eyebolt	Carbon Steel		

CLASS 150

SIZE	2	2½	3	4	6	8	10	12	14	16	18	20	24	26	28	30	36	in
	50	65	80	100	150	200	250	300	350	400	450	500	600	650	700	750	900	mm
L/L1 (RF/BW)	8.00	8.50	9.50	11.50	14.00	19.50	24.50	27.50	31.00	34.00	38.50	38.50	51.00	51.00	57.00	60.00	77.00	in
	203	216	241	292	356	495	622	699	787	864	978	978	1295	1295	1448	1524	1956	mm
L2 (RTJ)	8.50	9.00	10.00	12.00	14.50	20.00	25.00	28.00	31.50	34.50	39.00	39.00	51.50	-	-	-	-	in
	216	229	254	305	368	508	635	711	800	876	991	991	1308	-	-	-	-	mm
H	6.00	6.50	6.88	8.00	11.50	13.88	15.38	17.00	18.75	20.62	22.88	24.62	34.75	37.00	37.00	38.62	48.00	in
	152	165	175	204	293	353	390	432	475	525	582	627	883	940	940	980	1220	mm
WT (kg.)	14	20	25	40	71	118	177	263	353	542	632	855	970	1600	1600	1990	2760	RF
	10	12	17	29	57	96	143	227	295	468	552	755	831	1420	1420	1760	2230	BW

CLASS 300

SIZE	2	2½	3	4	6	8	10	12	14	16	18	20	24	26	28	30	36	in
	50	65	80	100	150	200	250	300	350	400	450	500	600	650	700	750	900	mm
L/L1 (RF/BW)	10.50	11.50	12.50	14.00	17.50	21.00	24.50	28.00	33.00	34.00	38.50	40.00	53.00	53.00	59.00	62.75	82.00	in
	267	292	318	356	445	533	622	711	838	864	978	1016	1346	1346	1499	1594	2083	mm
L2 (RTJ)	11.12	12.12	13.12	14.62	18.12	21.62	25.12	28.62	33.62	34.62	39.12	40.75	53.88	54.00	60.00	63.75	-	in
	283	308	333	371	460	549	638	727	854	879	994	1035	1368	1372	1524	1619	-	mm
H	6.00	6.50	6.88	8.00	11.50	13.88	15.38	17.00	18.75	20.62	22.88	24.62	34.75	35.88	37.00	38.62	48.00	in
	152	165	175	204	292	353	390	432	475	525	582	627	883	910	940	980	1220	mm
WT (kg.)	16	23	29	46	82	136	204	302	405	625	730	985	1115	1465	1840	2290	3180	RF
	11	13	18	31	61	103	155	245	315	503	593	812	895	1205	1525	1895	2395	BW

CLASS 600

SIZE	2	2½	3	4	6	8	10	12	14	16	18	20	24	in
	50	65	80	100	150	200	250	300	350	400	450	500	600	mm
L/L1 (RF/BW)	11.50	13.00	14.00	17.00	22.00	26.00	31.00	33.00	35.00	39.00	43.00	47.00	55.00	in
	292	330	356	432	559	660	787	838	889	991	1092	1194	1397	mm
L2 (RTJ)	11.62	13.12	14.12	17.12	22.12	26.12	31.12	33.12	35.12	39.12	43.12	47.25	55.38	in
	295	333	359	435	562	664	791	841	892	994	1095	1200	1407	mm
H	7.50	8.00	8.75	10.00	14.50	17.50	19.25	21.38	23.38	25.75	28.75	31.00	43.50	in
	190	205	222	255	368	445	490	540	595	655	730	785	1105	mm
WT (kg.)	24	35	44	70	125	207	310	460	615	945	1105	1495	1695	RF
	16	19	36	44	87	147	220	350	452	720	845	1160	1280	BW

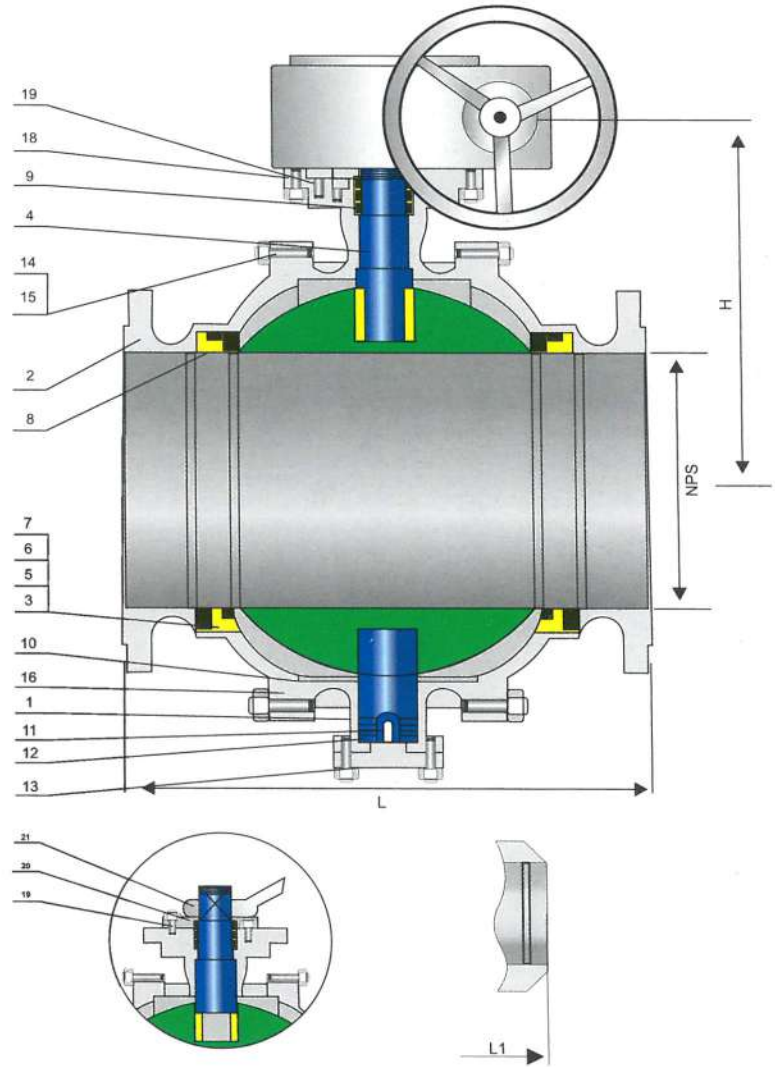

SIZE	15mm to 600mm above on request.
END	FE / SE / SW
RATING / CLASS	150 / 300 / 600 / 900 / 1500 / 2500 / PN 10 - PN 16
OPERATION	Lever / Gear / Electrical Actuator / Pneumatic Actuator / Cylinder
MOC	WCB, SS, FORGE STEEL, ALLOY STEEL

MATERIALS OF PARTS

NO	Part Name	ASTM Materials		
		Carbon Steel	18Cr-9Ni-2Mo	Carbon Steel
1	Body	A216-WCB	A351-CF8M	A350-LF2
2	Bonnet	A216-WCB	A351-CF8M	A350-LF2
3	Ball	A182-F3041	A182-F316	A182-F3041
4	Stem	A276-304	A276-316	A276-304
5	Seat	A105 + ENP	A182-F316	A305-LF2 + ENP
6	Seat Insert		Glass Filled PTFE	
7	Seat Spring	A313-304	Inconel X-750	A313-304
8	Seat O- Ring	NPR	Viton	Viton
9	Stem O- Ring	NBR	Viton	Viton
10	Bonnet Gasket	Graphite + 3042	Graphite + 3162)	Graphite + 3042
11	Bonnet O- Ring	NBR	Viton	Viton
12	Antistatic Spring	A313-304	A313-316	A313-304
13	Lower Cover	A216-WCB	A182-F316	A182-F304
14	Bonnet Stud	A193-B7	A193-B8	A320-L7
15	Bonnet Stud Nut	A194-2H	A194-8	A194-4
16	Trunnion	A276-304	A276-316	A276-304
17	Trunnion Bearing	304 + PTFE	316 + PTFE	304 + PTFE
18	Gland Flange	A216-WCB	A315-CF8M	A350-LF2
19	Gland Bolt	A193-B7	A193-B8	A193-B7
20	Stop Plate	Carbon Steel	Carbon Steel + Zn	Carbon Steel
21	Handle		Carbon Steel	

CLASS 150

SIZE	2	2½	3	4	6	8	10	12	14	16	18	20	24	26	28	30	32	36	in
	50	65	80	100	150	200	250	300	350	400	450	500	600	650	700	750	800	900	mm
L (RF)	7.00	7.50	8.00	9.00	15.50	18.00	21.00	24.00	27.00	30.00	34.00	36.00	42.00	45.00	49.00	51.00	54.00	60.00	in
	178	191	203	229	394	457	533	610	686	762	864	914	1067	1143	1245	1295	13.72	1524	mm
L1 (BW)	8.50	9.50	11.12	12.00	18.00	20.50	22.00	25.00	30.00	33.00	36.00	39.00	45.00	49.00	53.00	55.00	60.00	68.00	in
	216	241	283	305	457	521	559	635	762	838	914	991	1143	1245	1346	1397	1524	1727	mm
H	7.00	7.50	8.25	9.25	20.88	24.62	25.62	30.75	31.00	36.25	38.25	43.38	45.25	50.75	55.12	64.12	70.88	80.75	in
	177	190	210	235	530	625	650	780	790	920	970	1100	1150	1290	1400	1630	1840	2050	mm
W	14	16	20	20	24	24	24	24	32	32	32	32	32	320	32	32	32	32	in
	350	400	500	500	600	600	600	600	800	800	800	800	800	800	80	800	800	800	mm
WT (kg.)	15	19	27	38	81	140	160	205	260	390	510	750	1200	1400	1860	2100	2530	2970	RF
	13.5	15.5	24.5	32.5	76	132	147	182	241	370	455	726	1125	1250	1640	1930	2390	2760	BW

CLASS 300

SIZE	2	2½	3	4	6	8	10	12	14	16	18	20	24	26	28	30	32	36	in
	50	65	80	100	150	200	250	300	350	400	450	500	600	650	700	750	800	900	mm
L (RF)	8.50	9.50	11.12	12.00	15.88	19.75	22.38	25.50	30.00	33.00	36.00	39.00	45.00	49.00	53.00	55.00	60.00	-	in
	216	241	283	305	403	502	568	648	762	838	914	991	1143	1245	1346	1397	1524	-	mm
L1 (BW)	8.50	9.50	11.12	12.00	18.00	20.50	22.00	25.00	30.00	33.00	36.00	39.00	45.00	49.00	53.00	55.00	60.00	-	in
	216	241	283	305	403	521	559	635	762	838	914	991	1143	1245	1346	1397	1524	-	mm
H	7.00	7.50	8.25	9.25	20.88	24.62	25.62	30.75	31.00	36.25	38.25	43.38	45.25	50.75	55.12	64.12	70.88	-	in
	177	190	210	235	530	625	650	780	790	920	970	1100	1150	1290	1400	1630	1800	-	mm
W	14	16	20	20	24	24	24	24	32	32	32	32	32	32	32	32	32	-	in
	350	400	500	500	600	600	600	600	800	800	800	800	800	800	800	800	800	-	mm
WT (kg.)	19	24	34	48	101	175	200	255	325	485	635	935	1500	1750	2225	2450	2870	-	RF
	14	16	25	34	82	145	155	185	238	375	516	782	1280	1375	1825	2180	2260	-	BW

CLASS 600

SIZE	2	2½	3	4	6	8	10	12	14	16	18	20	24	26	28	in
	50	65	80	100	150	200	250	300	350	400	450	500	600	650	700	mm
L (RF)	11.50	13.00	14.00	17.00	22.00	26.00	31.00	33.00	35.00	39.00	43.00	47.00	55.00	57.00	61.00	in
	292	330	356	432	559	660	787	838	889	991	1092	1194	1397	1448	1549	mm
L1 (BW)	11.62	13.12	14.12	17.12	22.12	26.12	31.12	33.12	35.12	39.12	43.12	47.25	55.38	57.50	61.50	in
	295	333	359	435	562	664	791	841	892	994	1095	1200	1407	1461	1562	mm
H	7.12	7.62	8.50	9.50	21.25	25.00	26.12	31.12	31.88	36.38	38.75	44.50	46.62	52.50	57.00	in
	180	193	215	241	540	635	665	790	810	925	985	1130	1185	1335	1450	mm
W	14	16	20	20	24	24	24	24	32	32	32	32	32	32	32	in
	350	400	500	500	600	600	600	600	800	800	800	800	800	800	800	mm
WT (kg.)	26.	35	58	81	142	287	540	780	1000	1300	1700	2100	3400	3800	4500	RF
	19	25	42	51	85	200	395	610	805	1010	1350	1656	2775	3125	3790	BW

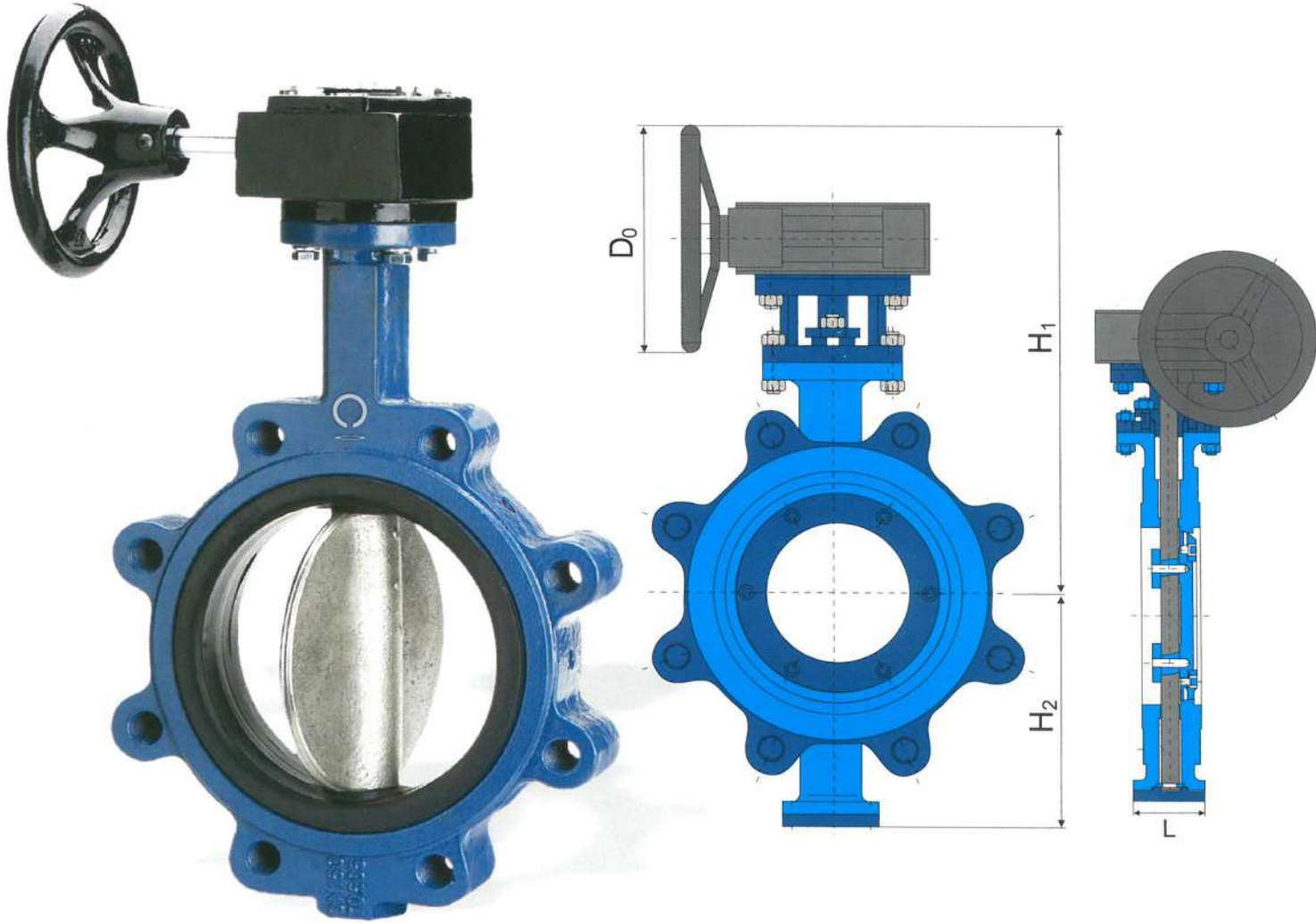

Wafer Type



Lugged Type



Double Flanged



Motor Operated

SIZE	40mm to 600mm above on request.
END	Wafer / Lugged Type / Double Flanged
RATING / CLASS	150 / 300 / PN 10 - PN 16
OPERATION	Manual Hand Wheel / Gear / Electrical Actuator / Pneumatic Actuator / Cylinder
MOC	WCB, SS, ALLOY STEEL

MATERIALS OF PARTS

PARTS	MATERIAL
BODY	CI / WCB / CF8 / CF8M / CN-7M
SLEEVE	NITRILE / EPDM / VITON / PTFE / SILICON
DISC	CI/ SG IRON / WCB / CF8 / CF8M / CN-7M
STEM	SS410 / 304 / 316 CN-7M
'O' RING	NITRILE / NEOPRENE / PTFE
WETHER SEAL	NITRILE / NEOPRENE / PTFE
GEAR BOX	ANY BEST INDIAN MAKE

CLASS 150

IN	DN	L	H1	H2	Do
2	50	43	305	115	160
2.5	65	46	315	125	160
3	80	48	330	135	160
4	100	54	360	150	160
6	150	57	515	185	280
8	200	64	530	240	250
10	250	71	550	275	250
12	300	81	660	315	320
14	350	92	670	330	350
16	400	102	730	365	350
18	450	114	810	390	350
20	500	127	890	430	400
24	600	154	940	470	400
28	700	165	1030	510	400
32	800	190	1150	570	450
36	900	203	1215	640	450
40	1000	216	1260	670	500
48	1200	254	1405	800	500

CLASS 300

IN	DN	L	H1	H2	Do
2	50	43	315	115	160
2.5	65	46	325	125	160
3	80	48	340	140	160
4	100	54	440	160	280
6	150	59	515	220	280
8	200	73	530	260	250
10	250	83	630	300	350
12	300	92	685	335	350
14	350	117	780	375	350
16	400	133	840	405	400
18	450	149	925	445	400
20	500	159	975	475	400
24	600	181	1075	540	450
28	700	-	-	-	-
32	800	-	-	-	-
36	900	-	-	-	-
40	1000	-	-	-	-
48	1200	-	-	-	-

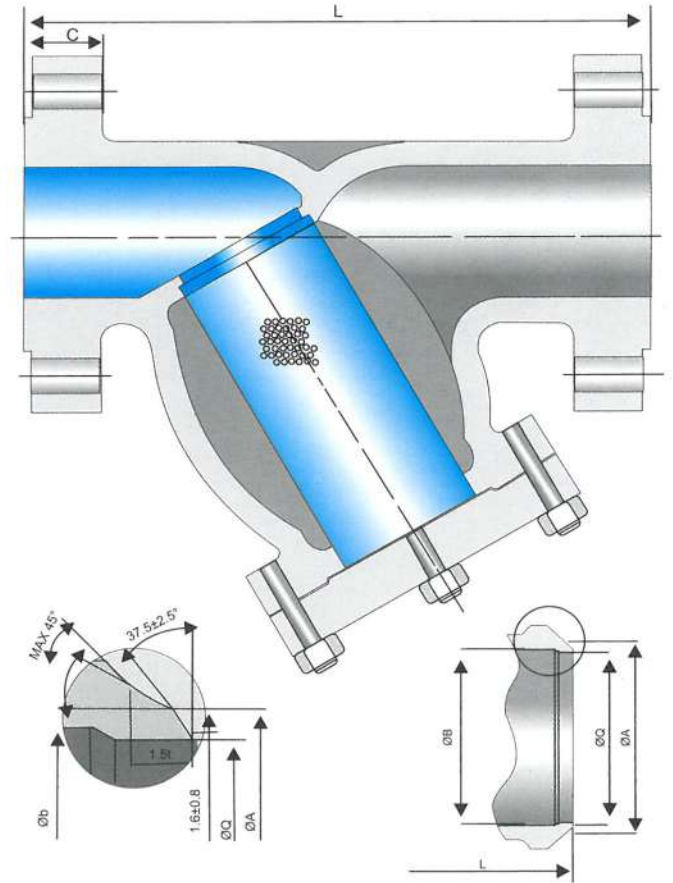

SIZE	15mm to 900mm above on request.
END	FE / SE / SW
RATING / CLASS	150 / 300 / 600 / PN 10 - PN 16
MOC	CI, WCB, SS

MATERIALS OF PARTS

PARTS	MATERIAL		
BODY	WCB	CF8	CF8M
SCREEN		SUS304	
GASKET		PTFE	
BONNET	WCB	CF8	CF8M
GASKET		PTFE	
STOPPER		CF8M	
SPRING WASHERS		SUS304	
BONNET BOLT	CARBON STEEL		SUS304

CLASS 150

SIZE		L	
inch	mm	RF	BW
½	15	108	-
¾	20	117	-
1	25	127	127
1¼	32	140	140
1½	40	165	165
2	50	203	203
2½	65	216	216
3	80	241	241
4	100	292	292
6	150	356	356
8	200	495	495
10	250	622	622
12	300	699	699
14	350	787	787
16	400	864	864
18	450	978	978
20	500	978	978
24	600	1295	1295
26	650	1295	1295
28	700	1448	1448
30	750	1524	1524
36	900	1965	1965

CLASS 300

SIZE		L		
inch	mm	RF	RTJ	BW
½	15	152	164	-
¾	20	178	191	-
1	25	203	216	203
1¼	32	216	229	216
1½	40	229	241	229
2	50	267	283	267
2½	65	292	308	292
3	80	318	333	318
4	100	356	371	356
6	150	445	460	445
8	200	533	549	533
10	250	622	638	622
12	300	711	727	711
14	350	838	854	838
16	400	864	879	864
18	450	978	994	978
20	500	1016	1035	1016
24	600	1346	1368	1346
26	650	1346	1372	1346
28	700	1499	1524	1499
30	750	1594	1619	1594
36	900	2083	2112	2083

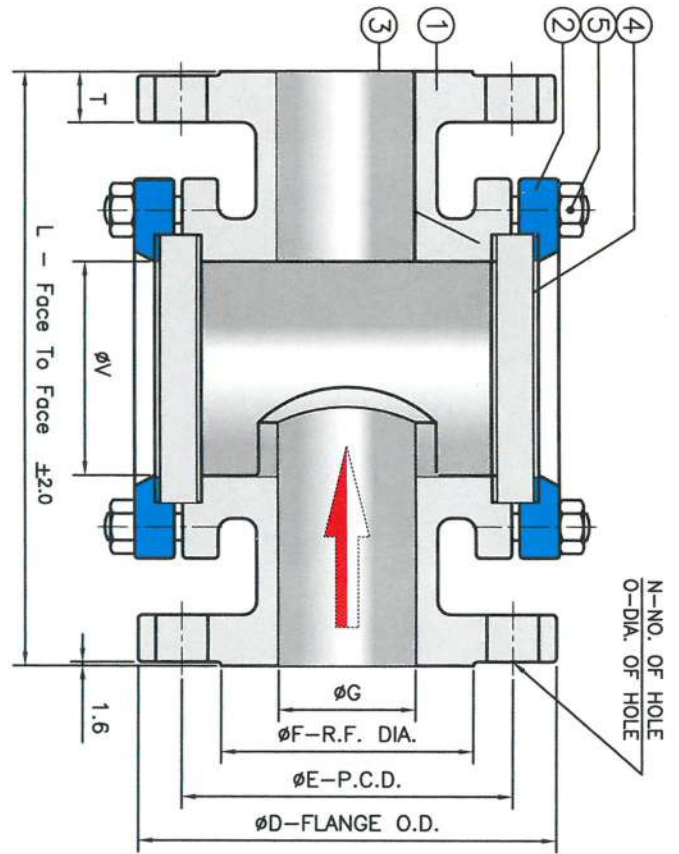

Fabricated



Tube Glass



Doble Window Glass



Tri Clamp Type

SIZE	15mm to 150mm above on request.
END	FE
RATING / CLASS	150 / 300
MOC	WCB, SS, FORGE STEEL, ALLOY STEEL

MATERIALS OF PARTS

PARTS	MATERIAL
BODY	A 216 Gr. WCB A 351 GR.CF8 / CF8M /CF3 / CF3M
COVER	M.S.FABRICATED TO IS 2062 AISI 304 / 316 / 304L / 316L
GASKET GLASS	P.T.F.E. TOUGHEN
STUD & NUT	A193 Gr. B7 / 2H / S.S. 304 / 316

DOUBLE WINDOW GLASS 150

SIZE	15	20	25	40	50	65	80	100
L	130	150	160	200	230	290	310	350
ØG	13	19	25	38	50	63	75	100
ØV	40	48	48	65	75	100	125	150
ØD	88.9	98.4	108.0	127.0	152.4	177.8	190.5	228.6
ØE	60.3	69.8	79.2	98.5	120.4	139.7	152.4	190.5
ØF	34.9	42.9	50.8	73.0	92.1	104.7	127.0	157.2
N	4	4	4	4	4	4	4	8
ØO	15.8	15.8	15.8	15.8	19	19	9	19
T	9.65	10.4	11.1	14.2	15.8	17.5	19	23.8

TUBE GLASS

SIZE	25	40	50	80	100
SIDE DIA	25	40	50	80	100
TOTAL LENGTH 11	125	125	125	125	125
H2	175	175	175	175	175
RACE FACE DAI	51	73	92	127	157
PCD	79.5	98.5	12.5	152.5	190.5
OD	108	127	152.5	191	229